

YOUR ADVENTURE UNFOLDS

# Khatsalano

with built-in coaming

*Feathercraft*  
FOLDING KAYAKS™

Feathercraft Products Ltd. 4-1244 Cartwright Street on Granville Island, Vancouver, British Columbia, Canada V6H 3R8  
Telephone: (604) 681-8437 Toll Free: 1-888-681-8437 Fax: (604) 681-7282 [www.Feathercraft.com](http://www.Feathercraft.com) [info@feathercraft.com](mailto:info@feathercraft.com)

# Contents

Khatsalano Single Folding Kayak .....	Page 2
Specifications .....	Page 3
Khatsalano Frame .....	Page 4
Care and Maintenance .....	Page 5
Khatsalano Assembly Instructions.....	Page 7
Disassembly .....	Page 29

# Khatsalano Single Folding Kayak



# Specifications

Frame:	6061 T6 Anodized Aluminum Seamless Drawn Round Tubing
Crossribs:	1/2" High Density Polyethylene
Rivets & Spacers:	Aluminum or Stainless Steel
Screws & Bolts:	Stainless Steel
Protective Coating:	Clear Anodized Aluminum Frame
Deck:	Polytech
Hull:	Duratek
Seat:	1/2" closed cell foam back & bottom, contoured plastic seat bottom, 3/16" plastic seat back with inflatable lumbar support, inside a 420 denier nylon seat cover.
Sponsons:	Welded Urethane
Standard Accessories:	Neoprene Spray Skirt Bow and Stern End Float Bags Adjustable Foot Braces Repair Kit Travel-style backpack Sea Sock Shockcord Cross-deck Tie Downs Perimeter Deck Line Assembly Video and Written Instructions

## Khatsalano

Length:	5.4 m (17'10")
Beam:	56 cm (22")
Weight:	20.5 kg (45 lbs)
Depth:	29cm (11.5")
Travel Style Pack Bag Size:	94 x 46 x 24 cm (37 x 18 x 10")
Assembly time:	35 minutes
Approximate Pay Load:	136 kg (300 lbs)

## Khatsalano-S

Length:	5.4 m (17'9")
Beam:	60 cm (23.5")
Weight:	22.25 kg (49 lbs)
Depth:	29cm (11.5")
Travel Style Pack Bag Size:	94 x 46 x 24 cm (37 x 18 x 10")
Assembly time:	35 minutes
Approximate Pay Load:	145 kg (319 lbs)

# Khatsalano Frame

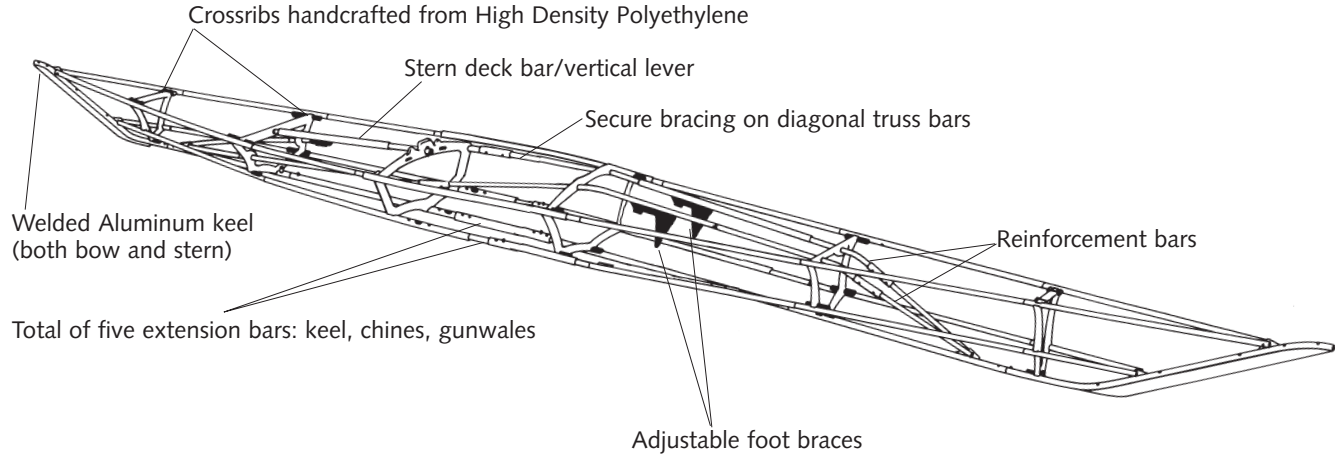

# Care and Maintenance

## THE FRAME

The tubular frame is very strong and corrosion resistant. We recommend that the frame be disassembled after extensive use (2-3 months). The inside and outside of the tubes should be washed with fresh water. Try to keep the inserts and extension bars free of sand and grit.

Included in your repair kit is a small dropper tube of Bo-Shield T-9. This product is made by Boeing and is an excellent lubricant and protectant for aluminum.

Aerosol containers of Bo-Shield can be found at marine hardware stores. We also have available 4 oz bottles of Bo-Shield. However, please note, that the lid closure is not suitable for shipping after the bottle has been opened. This container would be good for your "at home" clean-up. We also have available Super Lube. This is a teflon lubricant in gel form. This product is also available from bike shops.

Apply the Bo-Shield lubricant to frame tube inserts, spring buttons and sliding pieces prior to assembly. If you should leave your boat assembled for a maximum of two months, this will assist in preventing tubes seizing.

Other maintenance "musts":

- every two months completely disassemble the kayak.
- wash the frame completely with fresh water.
- reapply lubricant and/or wipe down tubes with Bo-Shield T-9.
- after paddling, sponge out the inside of the kayak. Do not allow water to pool along keel bar.

## THE SKIN

The Polytech deck and Duratek hull are urethane. Seams are permanently sealed.

A patch kit is provided for deck, hull or sponson punctures. One urethane glue will work for repairs to all of these fabrics.

## SPONSONS

Due to tight fit of the skin, the sponsons are under considerable pressure and some seepage of air may occur. It is advisable to periodically reinflate the sponsons.

#### TO REPAIR/REPLACE SPONSON

The sponsons can be completely removed from the sleeve sewn to the inside of the skin. Turn the skin inside out. The sponson chamber is open at bow and stern ends. Tie a long string through the hole in the tab at each end of sponson. Pull sponson through the center opening of the chamber (where sponson hose is attached). To reinstall, pull the cord attached to the new sponson back through the chamber. Ensure sponson is not twisted in the chamber. Urethane glue and patches are included in the repair kit. Duct tape works well on the sponsons.

#### STORAGE

Once clean and dry, the kayak can be stored assembled or disassembled in a shaded, dry place. When storing the kayak disassembled, take extension bars apart.

1 SET OUT FRAME PARTS AS ILLUSTRATED.

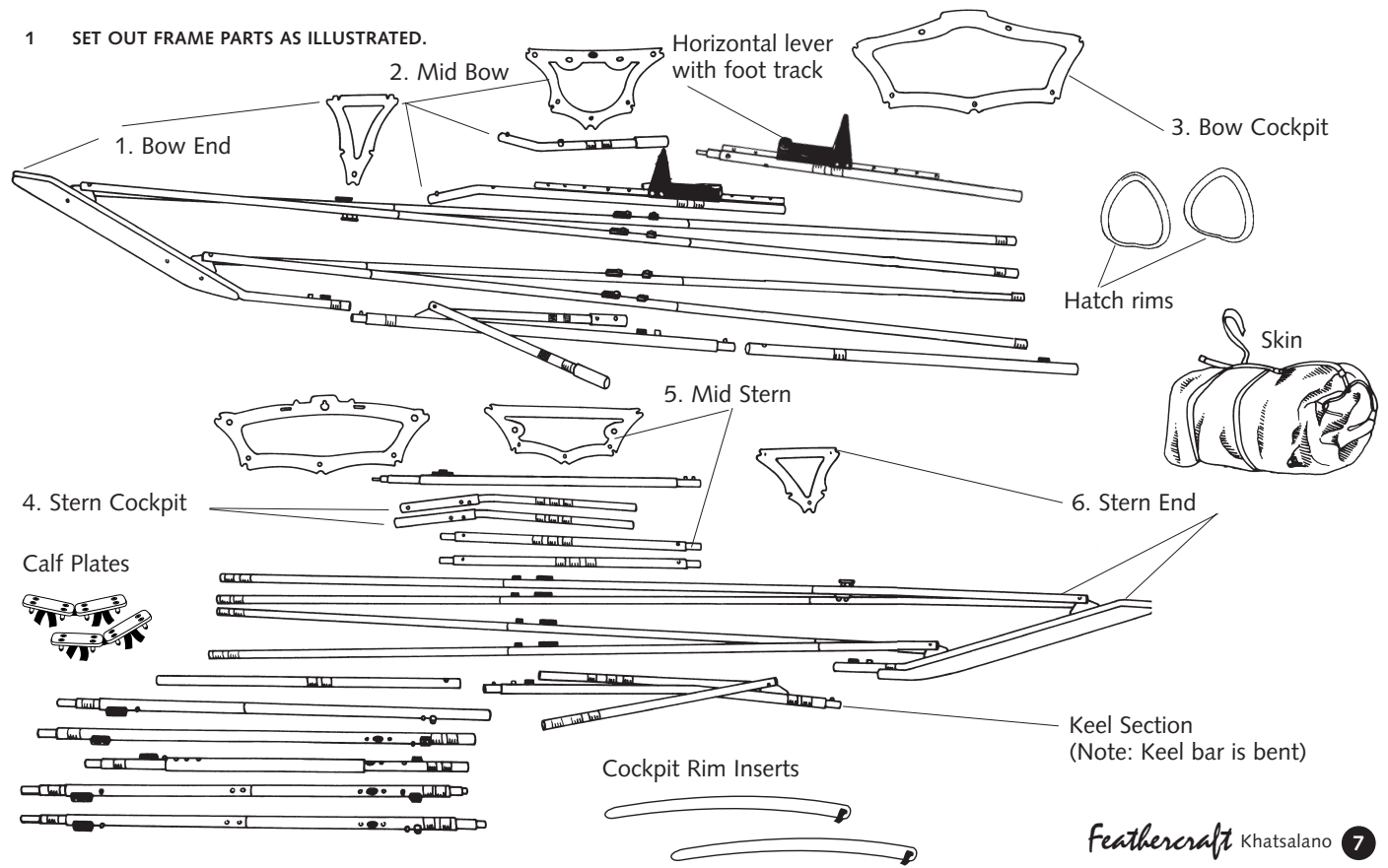



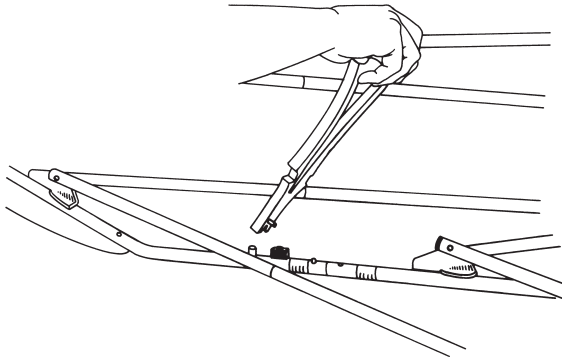
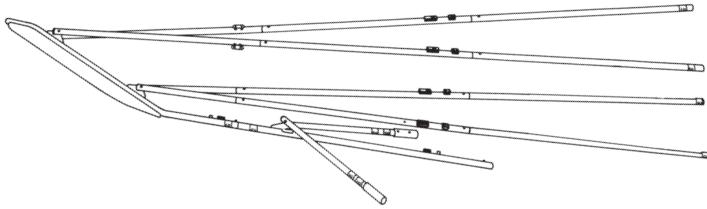

## 2 BOW SECTION.

- The Bow Rib tubes have a single band of coloured tape (red, green, yellow, blue and black).
- The Bow Reinforcement Bars have one band of coloured tape and one band of white tape.
- Fold out bow section. Shockcorded tubes take shape. Attach second Bow Keel Assembly (with one welded plate and two tubes attached, one black tape.)
- Attach keel bar with black plastic block and hole for spring button.

## 3 ATTACH SMALL #1 CROSSRIB TO BOW SECTION.

- There are six high density polyethylene Crossribs. Each one is numbered.
- Tilt crossrib above Keel Bar. Pin on small crossrib is inserted into hole in plastic block on keel tube.
- Attach Gunwale tubes in notched connection on upper section of crossrib.

Block in open position

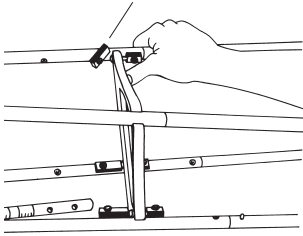

Block in closed position

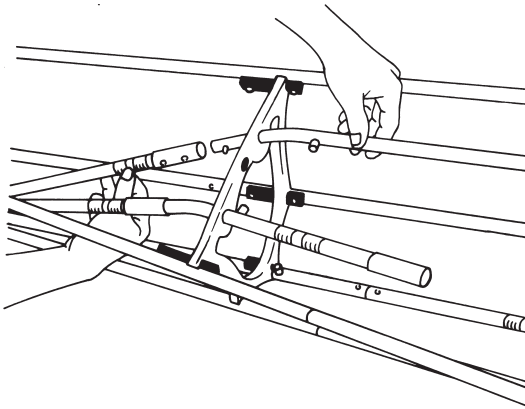
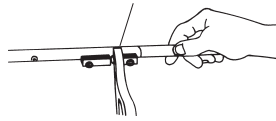

- 4 **ATTACH MID #2 CROSSRIB TO BOW SECTION.**
  - Attach keel as in Step 3.
  - Attach to gunwales. Turn plastic block to lock into place. Turn the tube so the two rivet heads face inward, towards keel.
  - Attach to Chines.
  - Check that chines are properly aligned with #1 Rib.
  
- 5 **ATTACH LEFT AND RIGHT BOW END REINFORCEMENT BARS.**  
(bent, with spring buttons: the right one with green tape is longer).
  - Slide through the two holes in the #2 Crossrib and attach.

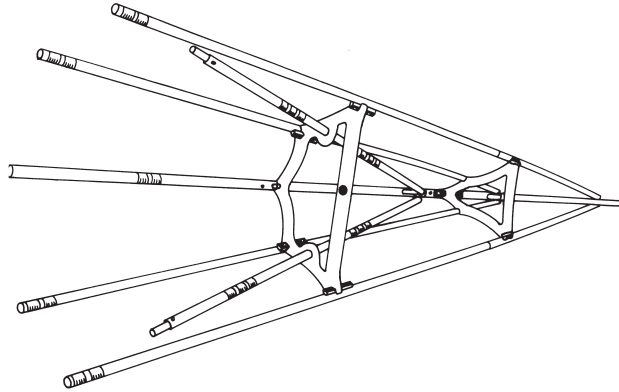

**6 ASSEMBLE STERN SECTION.**

- The Stern Rib tubes have two bands of coloured tape (red, green, yellow, blue).
- The Stern Reinforcement Bars have two bands of coloured tape and one band of white tape. The white tape of all Reinforcement Bars is always oriented towards the bow of the kayak frame.
- Repeat Steps #2,#3,#4, and #5.

**7 ROLL OUT SKIN.**

- Slide Bow and Stern sections into skin. (Feathercraft label is on the bow end).
- Ensure that the frame is centered in the skin!

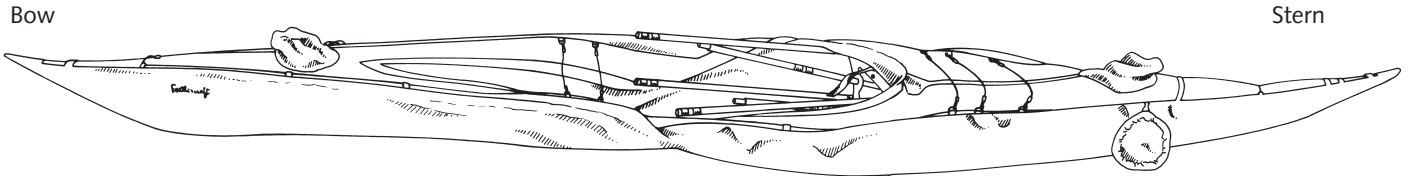

- Attach the two velcro closures on the inside keel of the hull to keep the frame in place.

Keel extension bar

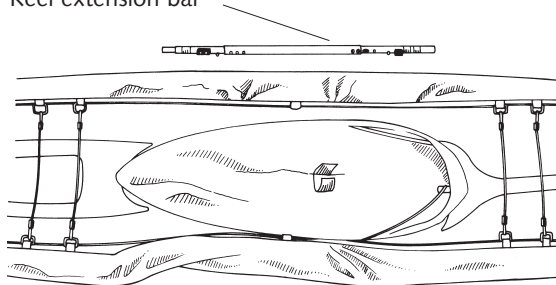

Bow deck bar/horizontal lever

Stern deck bar/  
vertical Lever

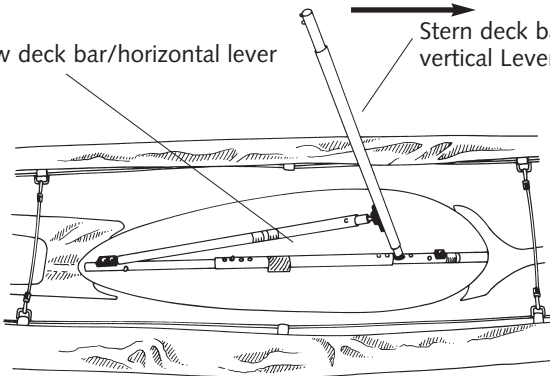

During additional assembly steps, keep re-checking that the frame has remained centred in the skin.

**8 INSTALL KEEL EXTENSION BAR.**

- Wrap velcro closure around tube.

**9 EXPAND KEEL EXTENSION BAR.**

- Attach Keel bar to bow and stern section Keel bars.
- Lever extension bar using Stern Deck Bar/ Vertical Lever and Bow Deck Bar/Horizontal Lever.
- Expand until spring button pops up in first hole. An additional “pusher” block has been installed on the bow keel bar. If the bow and stern sections need to be separated further to insert the keel bar, push against this block using the lever bars.

**10 INSTALL RIGHT (BLUE) AND LEFT (YELLOW) CHINE EXTENSION BARS.**

- Expand Chine Extension Bars to first hole.

**11 EXPAND KEEL EXTENSION BAR TO SECOND POSITION.**

- Depress spring button. Lever until spring button pops up into the third hole.

(Please Note: Some steps have been shown with frame only for illustration purposes.)

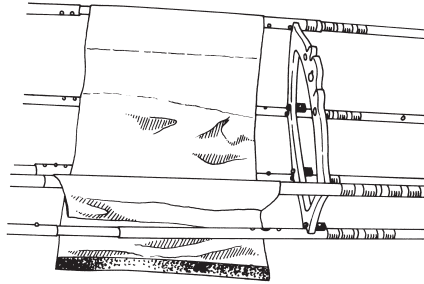

**12 EXPAND CHINE EXTENSION BARS TO SECOND POSITION.**

- Note: There are four holes in the Keel Extension Bar and three holes in the Chine and Gunwale Extension Bars. Expand to these positions if the skin slackens after extended use.

**13 INSTALL SEAT SLING AND GUNWALE EXTENSION BARS.**

- Stern end of seat sling has narrower stitching. Slide Left and Right Gunwale Extension Bars through loops in sling. Attach Gunwale Extension Bars to frame and expand to first hole. Slide lower flaps of seat sling under Chine Bars. (Do not attach velcro until #3 and #4 Crossribs are in place). Expand Gunwales to second position.
- At this point ensure that the entire frame is straight. Look down the entire kayak. You may have to rotate the bow or stern end slightly.

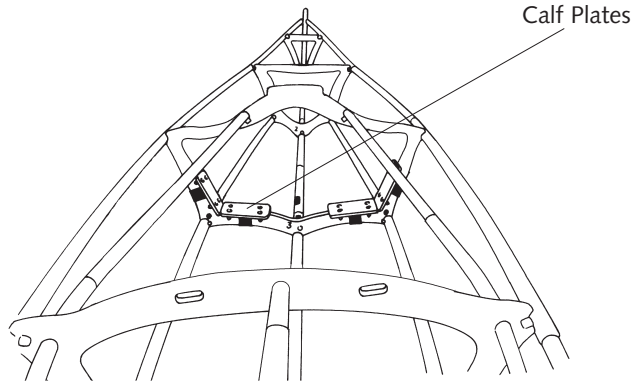
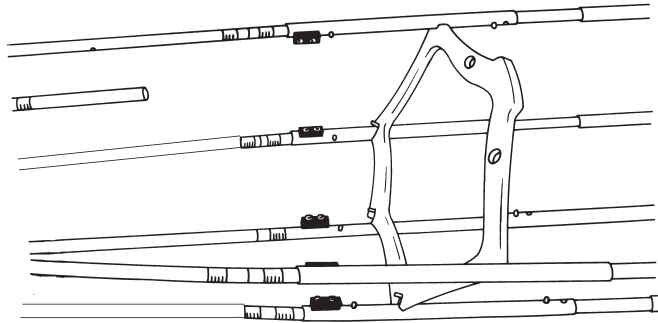

#### 14 INSTALL #3 CROSSRIB.

- Place Crossrib directly above the keel and chine bars (forward of the seat sling) and push down.
- Tilt the Crossrib back towards the Stern and engage the two Gunwale bars.
- Straighten the crossrib and slide forward until it is near the spring buttons that protrude from the keel and chine extension bars.

- Rotate the keel and chine extension bars until the screws that protrude from the crossrib align with the holes in the black plastic blocks.

Note: (The lever bar can be used to help rotate tubes. Insert pin into hole used when you extended the frame. Rotate to align.)

- Rotate the two gunwale extension bars until the black blocks attached to them face towards the middle of the cockpit.
- Depress one of the gunwale spring buttons and slide the crossrib over it. Do the same with the chine and keel bars and then the other gunwale and chine bars.

#### CALF PLATES

- Install the plastic plate supports by wrapping Velcro around Crossrib #3.

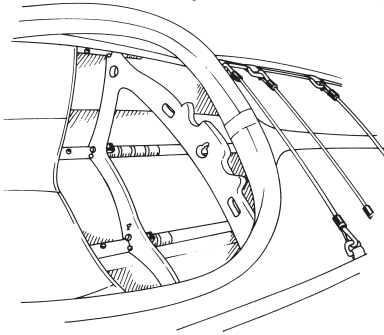

**15 INSTALL #4 CROSSRIB.**

- Position the #4 crossrib aft of the seat sling and complete like #3.
- Complete seat sling by securing "velcro sandwich" around chine bars.

**16 INSTALL BOW REINFORCEMENT BAR/  
HORIZONTAL LEVER.**

- Attach to Left Bow End Reinforcement Bar.
- Slide footbraces onto track.

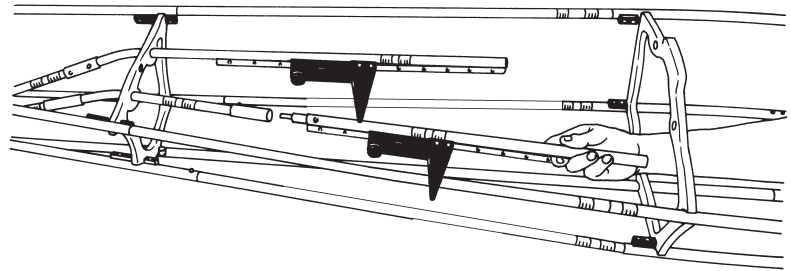

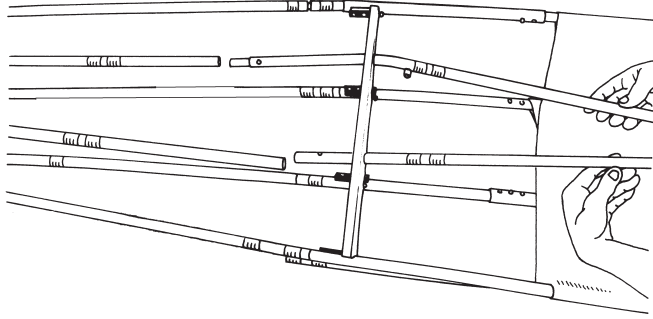

**17 INSTALL BOW COCKPIT REINFORCEMENT BARS.**

- Slide the two bars from the cockpit through the large holes in the #3 Crossrib. Attach to the bow reinforcement bars.

**18 INSTALL STERN COCKPIT REINFORCEMENT BARS.**

- Slide the two bars from the cockpit through the large holes in the #4 crossrib. Attach to stern end reinforcement bars.

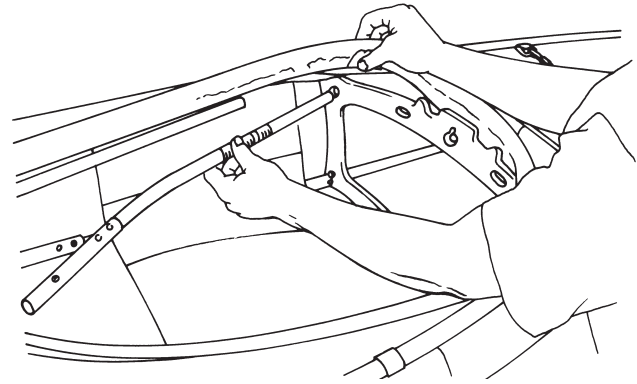



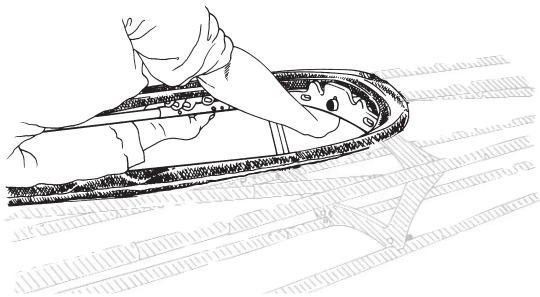

**19 CONNECT THE COCKPIT REINFORCEMENT BARS.**

- Slide the sleeve on the stern bars over the bow bars until the spring buttons pop up in the first holes.
- (The technique shown works best.)

**20 INSTALL RIM INSERTS.**

- Webbing strap wraps around gunwale and thigh brace.

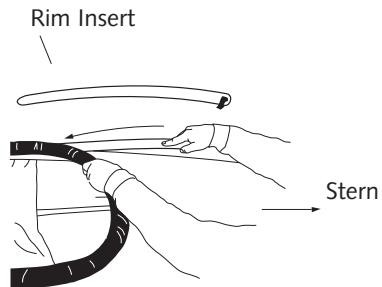

Slide into pocket on underside  
of coaming rim

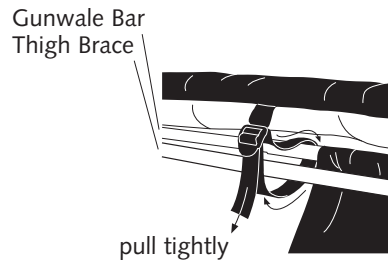

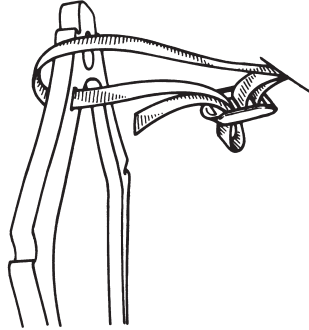

**21 ATTACH WEB LOOPS TO #4 CROSSRIB.**

- On the inside of the deck behind the #4 crossrib are pieces of webbing. Install over crosspiece and then back through the slot in the crosspiece. Secure to ladderlock buckle.

**22 INSTALL STERN DECK BAR/VERTICAL LEVER.**

- Put the stern deck bar through the center of the large #4 crossrib: end with black block pointing toward the stern. Bring deck bar back through hole in top of #4 Crossrib. Line up bar, and insert stern end into hole drilled into the top of the #5 crossrib. Rotate deck bar to lock into place.
- Cinch web loops (#21) to hold firmly in place.

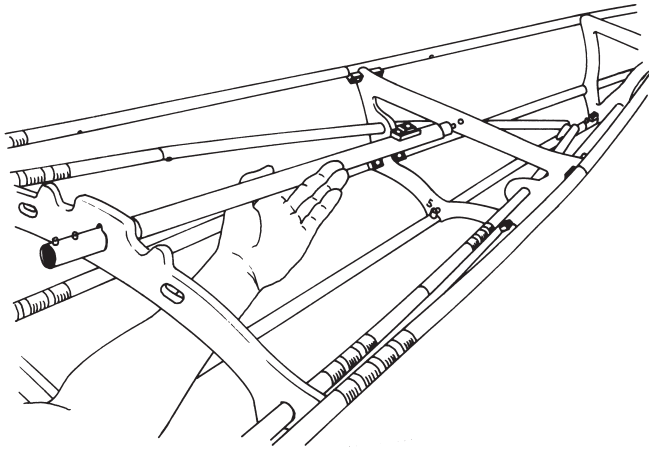

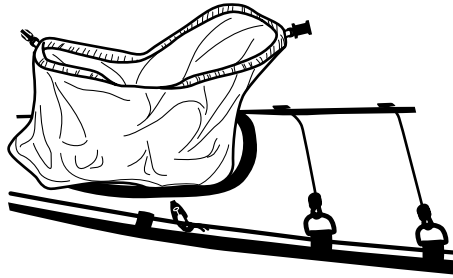

23 ATTACH HATCH RIMS.

Place the small plastic bow hatch rim over the opening on the bow deck, with the small end towards the bow. Roll the fabric over the rim. Repeat with the larger stern hatch.

Note: Remove hatch rim when rolling up skin.

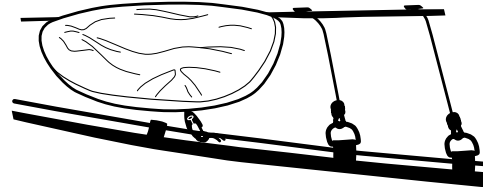
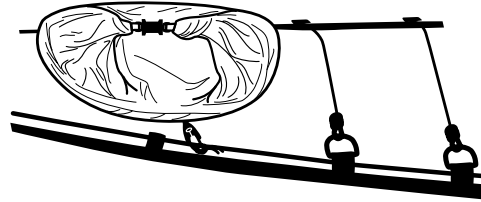

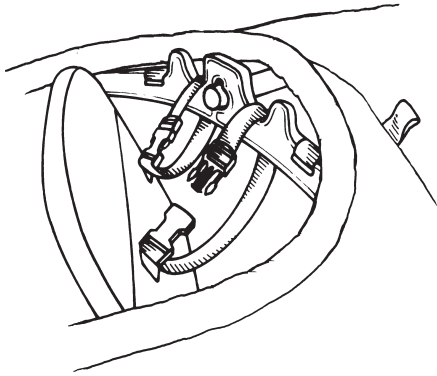

#### 24 INSTALL SEAT.

- Loop webbing at top of seat over #4 crossrib and connect to buckle.
- Loop webbing at front of seat around the side of #3 crossrib and connect to ladderlock buckle.
- Note: webbing goes above chine bar.
- Note: this seat has special side straps that enable it to be used as a beach chair

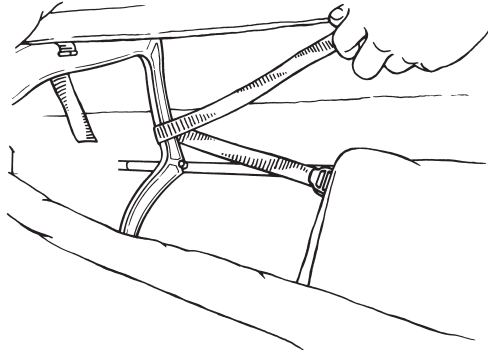

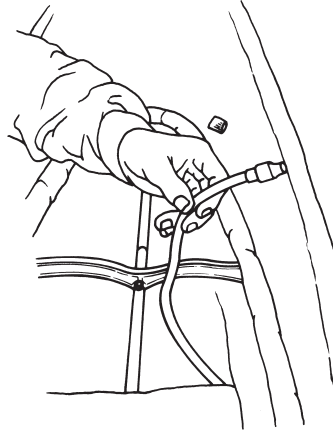

## 25 INFLATE SPONSONS.

### FOR KHATSALANO-S

- Turn the top of the valve to open. When inflating sponsons, alternate sides to ensure the frame and skin remain centered. The air pressure from the sponsons can shift the frame within the skin. Keep blowing until the skin is nice and tight. Twist top cap to close. Tuck sponson tubes and valves out of the cockpit area. Avoid stepping on the hose and valve, and try to keep the valve free of sand.

### FOR KHATSALANO (REGULAR)

- Smaller diameter sponsons have been installed in the skin. You can choose to paddle the boat with the sponsons inflated or not. Inflating the sponsons creates a slightly rounder chine. Leaving the sponsons deflated will leave the boat with a hard chine and will be slightly more tender.

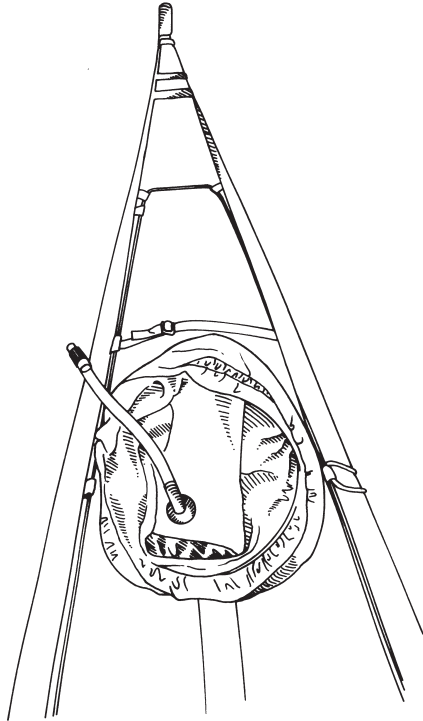

## 26 INFLATE FLOTATION BAGS.

- Insert the two end flotation bags through the bow and stern hatches and inflate. Always use these bags unless the bow and stern are filled with gear in water-proof bags.
- We recommend that you also insert and inflate the optional mid bow and main stern flotation bags.

You can't have too much flotation!

- Secure hatch cover.

## The Feathercraft Sea Sock

Made from high-quality coated nylon, the sea sock is a great safety item. The top of the sock fits tightly around the cockpit coaming rim. Contoured to fit along the seatback and bottom, the “foot” is loose through the cockpit, creating a “pod”. The paddler then sits in the sock. Legs and feet are not constricted. The spray skirt fits as usual. In the event of a capsize, water will only enter the sock, and not the whole boat. It's also great for keeping the inside of your kayak clean.

## Tips on Usage and Installation

- The shiny side of the fabric faces in towards the kayak frame.
- When facing the bow of the kayak, the Feathercraft label should be on the right side.
- The center seam on the up-side of the Sea Sock should be centered on the bow point of the coaming.
- Once the Sea Sock is in place, sit in the sock, and “burp” it by lifting the edges, releasing trapped air that causes the sock to billow up.

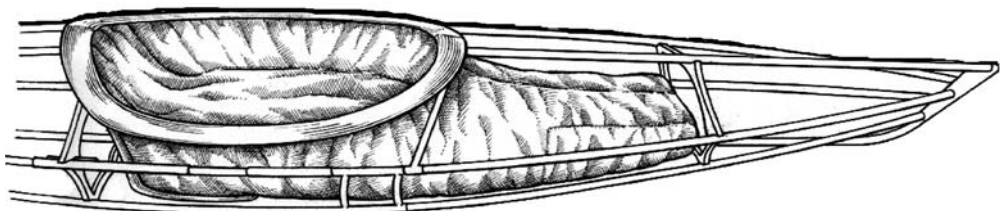

Diagram A

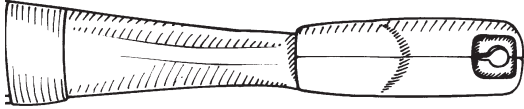
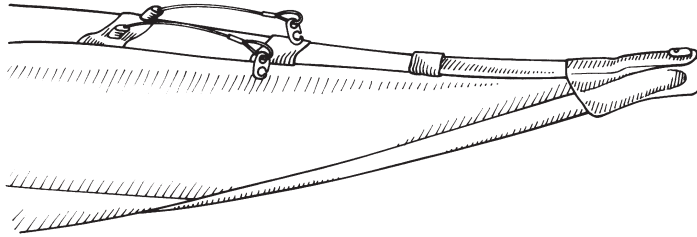

Diagram B



## Khatsalano Surf Rudder

The stern end cap is the rudder mount, and is permanently attached to the stern of the kayak. (Diagram A)

The stainless steel pin extending from the base of the rudder is inserted through the "key hole" of the stern end cap/rudder mount.

Rotate rudder head until fin is facing towards the bow.

The stainless steel rudder cables coming through the stern deck have one sister clip. (Diagram B)



Diagram C

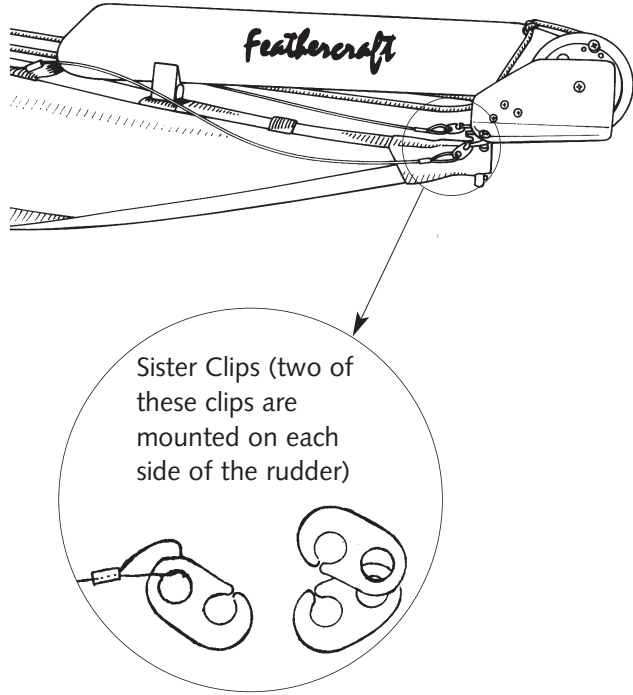

Join these to the two sister clips attached to each side of the rudder. (Diagram C)

Attach the bungee cord with the hook to the loop on the deck to the rear of the cockpit.

The rudder haul cord runs along the deck and is attached to the clip.

When seated in the kayak, pull the knot on the haul cord that is farthest from you to raise and lower the rudder fin.

**A CONNECTING RUDDER CONTROL TO FOOT BRACE**

- Red webbing adjusters are connected to the foot brace. Unscrew thumb-knob on foot brace; stem of knob goes through grommet. To make the adjuster shorter, fold webbing over to second grommet. Re-attach knob to foot brace. Slide brace on to track. Ensure brace can slide easily on track. (If not, check knob that you re-attached.) If additional leg extension is required, the brace foot plate can be reversed.

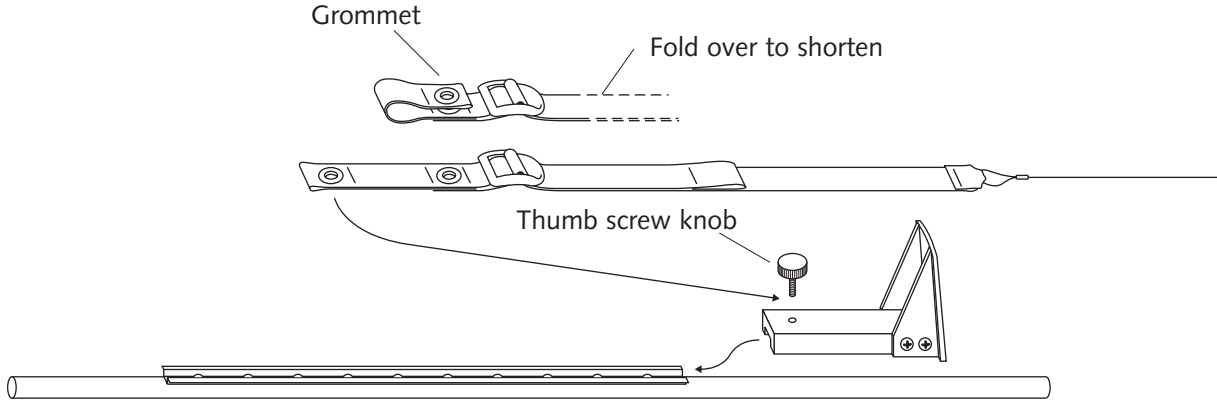
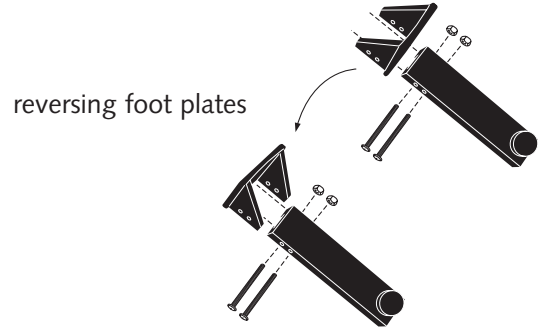

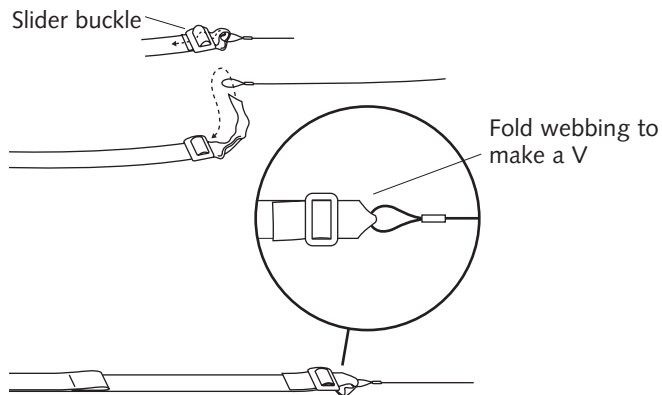

**B CONNECT CABLE ADJUSTER TO STAINLESS STEEL CABLE.**

- This is to attach the adjuster if you have installed the rudder from a kit.
- Slide end of webbing through slider buckle. Thread the webbing through the loop in the stainless steel rudder cable. Fold or "pinch" webbing to make a V. Re-thread webbing through slider buckle.

**C CABLE LENGTH ADJUSTMENT**

- To shorten cable length, pull on tab of webbing with loop; to lengthen, lift tab of ladder-lock buckle.

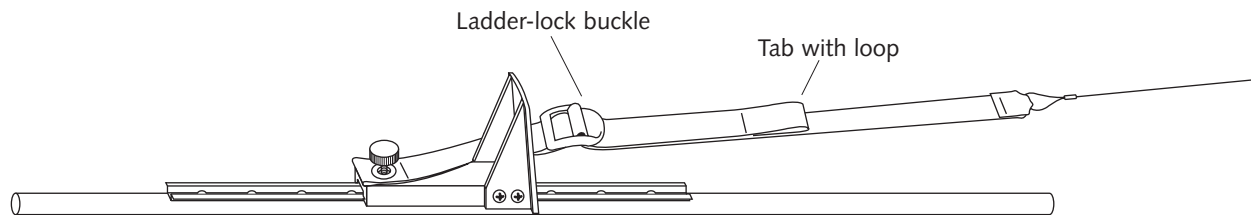

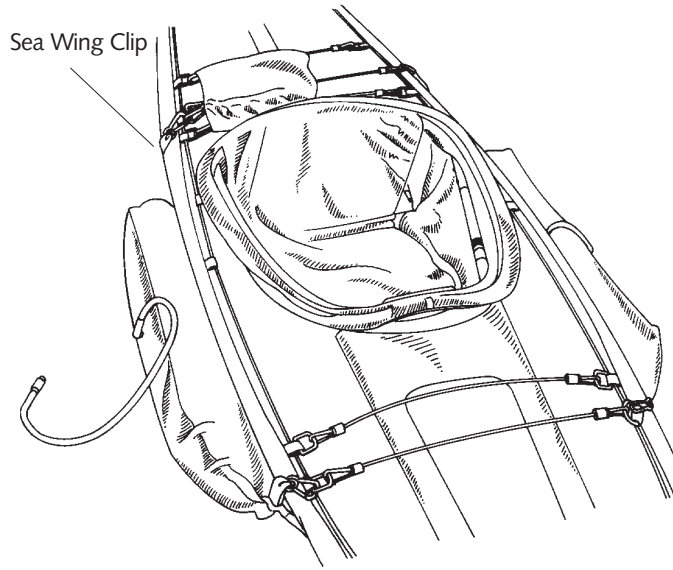

## Available Options

### SEA WINGS.

Sea Wings are external air tubes used for self-rescue re-entry.

- The red webbing deck loop corresponds to the clip with red tab on the Sea Wings.

### OPTIONAL FLOAT BAGS.

Mid-Bow Float Bag

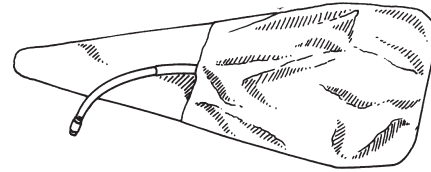

Main Stern Float Bag

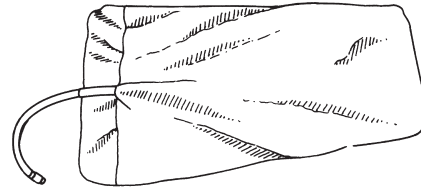

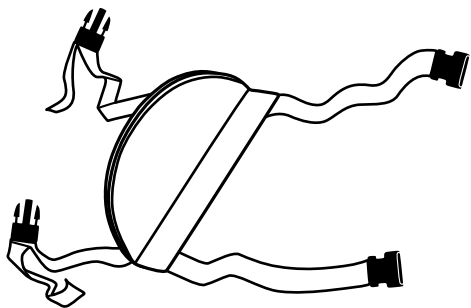

#### STRAP-ON SKEG FOR KHATSALANO KAYAK

Skeg placement on stern.  
(Tapered end towards bow)

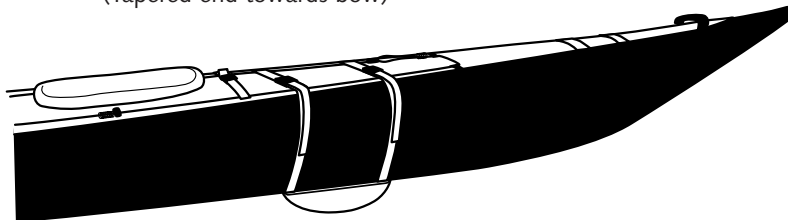

To prevent the skeg sliding backwards, loop the webbing strap underneath the stern deck strap.

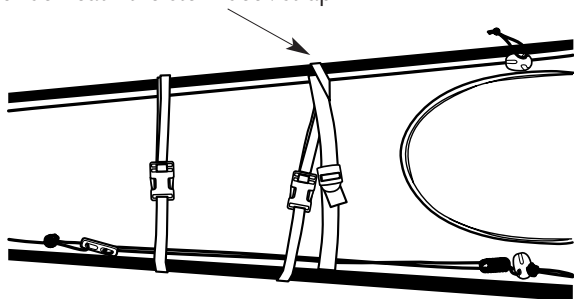

## Disassembly

To disassemble, remove rim inserts and hatch rims.

Then reverse the order of the assembly steps. When taking down the five extension bars, start with the two gunwale bars first, then the two chine bars, and finish with the keel extension bar. To depress the spring buttons, the stainless steel pin on either of the Lever Bars can be pushed against them. For the final Keel Extension Bar it is best to set up the Lever system as in Step #9 to release tension.

## Folding the Skin

Pull out the hoses attached to the sponsons and open the valves. Remove hatch rims. Fold the bow and stern ends towards the middle of the skin. Fold half of the skin over onto the other half. Roll up the skin toward the mid point where the sponson hoses are located. This will ensure that air in the sponsons is forced out. Close the valves on the sponson hoses and tie the skin. Roll up tight and snug.

## Packing the kayak in the bag

- Put the seat cushion in the bag first, with the cushion facing down, to give padding for your back.
- Next arrange the white plastic crossribs and hatch rims over the seat.
- Roll the kayak skin up tightly—fold the ends to the center of the kayak; fold in half; roll tightly; secure with webbing ties.
- Put the bow frame parts on one side of the bag, and the stern parts on the other.
- Place the folded skin between the frame parts.
- All the remaining tube frame parts are then placed over the bow and stern section bundles.
- Place the flotation bags over the frame parts.
- Spread the sea sock over the frame parts to protect the tubes.

© Feathercraft Products Limited 1998  
Printed in Canada 12.2005  
Recycled paper

